

## The Communications & Power Industries LLC Modular Block Converter (MBC) System eliminates downtime and maximizes performance and ease of repair by providing fully modular systems for up conversion or down conversion.

Modular converter units upconvert an IF uplink frequency block to a corresponding Ku-Band RF transmit frequency block, or downconvert a Ku-Band RF receive frequency block to a corresponding IF downlink frequency block.

Leveraging patented technology and field proven architecture, all of the critical system components are hot-swappable without the removal of power and can be removed from the front of the chassis with the exception of the fan assembly which is accessible from the rear panel.

### Hot-Swappable Architecture

The converters can be configured for single-thread operation or for 1:1 or 1:2 redundancies. In a redundant system, a backup converter can be switched in automatically or manually to replace a faulted unit; the faulted module may be removed or replaced while the others remain operational.

The system design leverages a blind mate backplane for front panel removal of converters, power supplies, logic card, and color touchscreen. The design enables fast and easy repair with continuous operation, achieving MTTR of less than 3 minutes.



Hot-swappable, plug-in upconverter and downconverter modules

Dual, redundant, hot-swappable power supplies

Excellent frequency stability over temperature

Built-in monitoring of individual modules and overall system performance

Internal/external auto-switching  
5 or 10 MHz reference

### FEATURES:

- Front hot-swappable plug-in modules (RF, PS, touch screen, and logic card).
- Available in stand-alone, 1:1 redundancy, and 1:2 redundancy configurations
- Color touch-screen user interface
- TCP/IP embedded page to monitor and control system functions
- Ethernet or Serial I/O M&C interface
- Standard 19" rack panel, 3.5" high (2 RU), with 22" chassis slides; chassis is 24" deep

### RF Module Bands

#### Downconverters

Input	LO Frequency	Output	Model
10.70-11.75 GHz	9.75 GHz	950-2000 MHz	DKFX
11.70-12.75 GHz	10.75 GHz	950-2000 MHz	DKJX

#### Upconverters

Input	LO Frequency	Output	Model
950-1700 MHz	12.80 GHz	13.75-14.50 GHz	UKBX

## User Interface - Leading Edge Software

The MBC is equipped with a color touch-screen for local control along with a leading edge TCP/IP embedded Web Page software package. The software can be configured for remote monitoring, while allowing virtual factory access to monitor the converter modules' key performance parameters such as temperature, current, and voltage. The user interface features secure login with user privilege level controls.

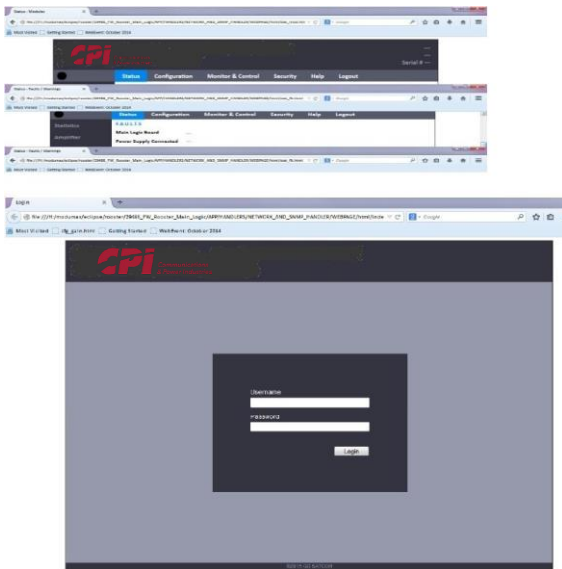

## Operating Functions

- Monitors and controls two or three redundant RF modules of a single type in either a 1:1 (two module) or 1:2 (three module) configuration.
- Monitors and controls one, two or three independent, single-thread modules.
- Monitors cooling fan speed for faults
- Monitors the internal power supply modules for faults.
- Front panel controls and status indicators
- Ethernet Interface:
  - SNMPv1/2/3
  - HTTPS (Web page)
  - Firmware Updates via secure protocol

- RS-232/485/422 Serial Interface
- Redundant Control Modes:
  - Auto Mode: A faulted RF module is automatically switched off line and replaced with the backup unit.
  - Manual Mode: Allows manual control over which unit is online, via the front panel, serial port, or network.
- Converter modules feature an auto selection reference that automatically phase locks to an external 5 or 10 MHz reference when present, or uses its internal high stability reference when the external reference is not detected.
- Built-in RF module monitoring & control capabilities:
  - Gain Adjust or attenuation control
  - External Reference Level
  - External Reference Frequency
  - Reference Phase Lock
  - LO Phase Lock
  - Module Current
  - Module Power-On Self-Test
  - Module Temperature

## Auto-recovery and Sparring

- The MBC senses loss-of-lock conditions and component failures to initiate switching to a redundant converter. Users have the capability of setting up remote monitoring via embedded TCP/IP web status pages. Replacement of any component can be accomplished within minutes.
- Sparring of the MBC is dependent upon the user.
- Active components that are hot-swappable
  - RF Converter Module
  - Logic Module
  - Power Supply Module
  - Touchscreen Display Module
  - Fan Assembly

## Cooling Fans

- The MBC has two cooling fans mounted on an easy-to-replace fan assembly.

1 for 1 (1:1) Redundant Downconverter System

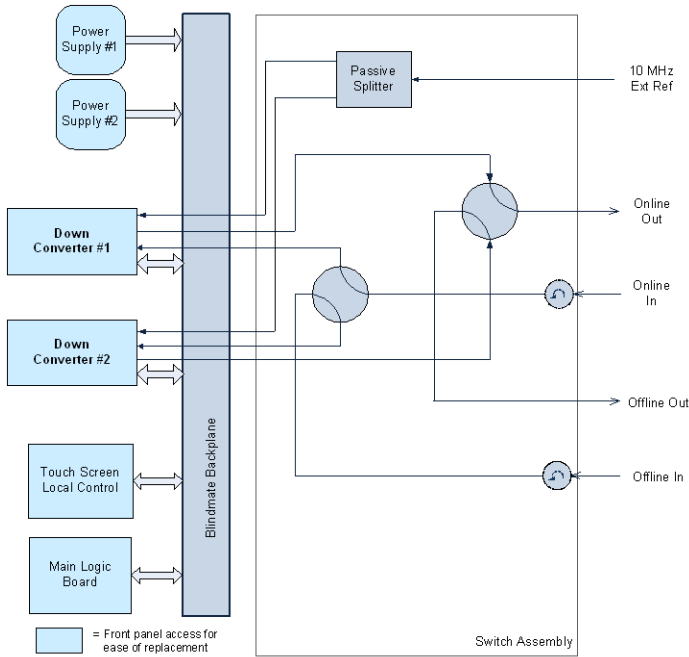

1 for 1 (1:1) Redundant Upconverter System

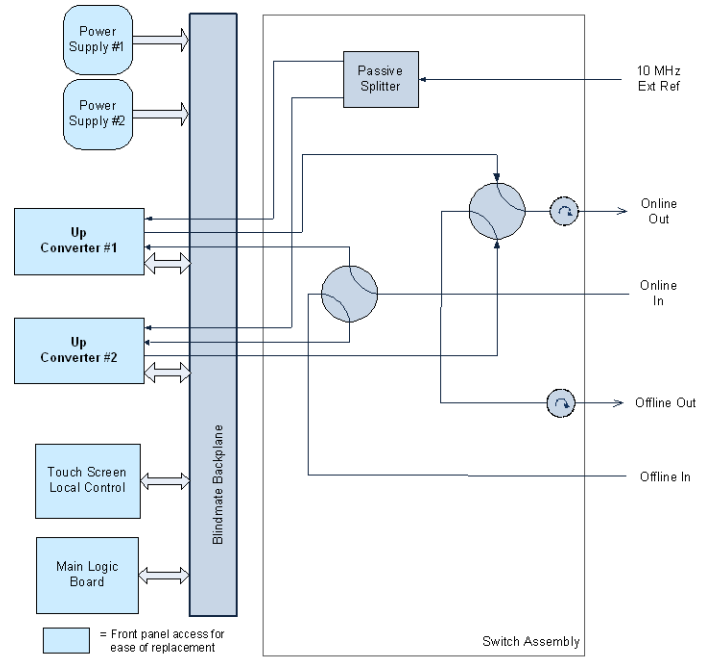

1 for 2 (1:2) Redundant Downconverter System

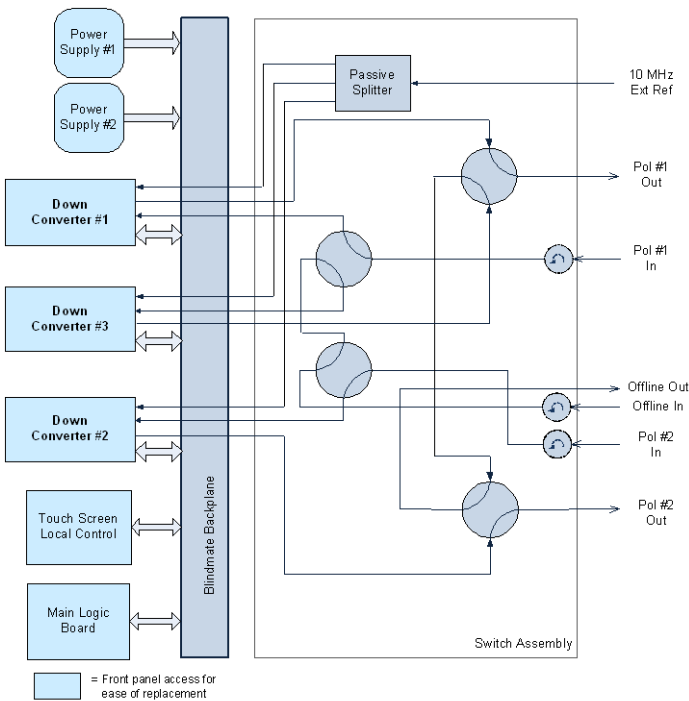

1 for 2 (1:2) Redundant Upconverter System

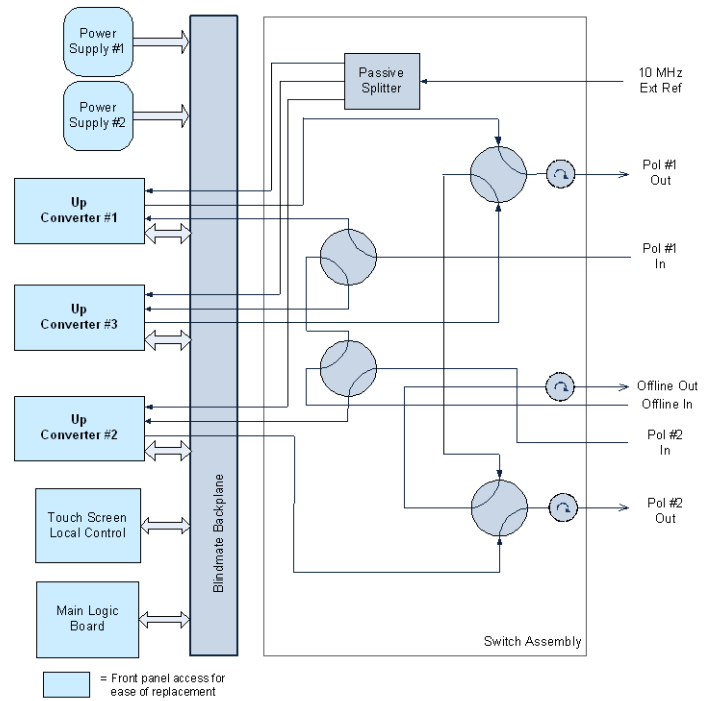

## Downconverter Module Performance

Parameter	Notes	Specification
RF Input Power		-10 dBm at maximum gain
RF Input VSWR		1.25:1 max. ratio 19.1 dB Return Loss min.
RF Output VSWR		1.5:1 max. ratio 14 dB Return Loss min.
LO Leakage		150 dBm max. at IF Output
Reference input Frequency		5 or 10 MHz typical, Auto Detect
Reference input Power		-7.5 dBm min., 0 dBm typical, +7.5 dBm max., At module
Power Output at 1dB compression (P <sub>1dB</sub> )	IF Output, at max. gain	+15 dBm min., +17 dBm typical
3 <sup>rd</sup> Order Output Intercept Point	IF Output, at max. gain	+26 dBm min., +28 dBm typical
Gain		24 dB min., 26 dB typical, 30 dB max., at max. gain setting
Gain Step Resolution	Standard LNA	0.1 dB typical
Adjustable Gain Range		25 dB typical
Gain Flatness		±1 dB over the full band ±0.25 dB per 40 MHz
Gain Stability	Per day, Over temperature Per week, Constant temperature Per week and over temperature	±1 dB typical ±0.5 dB typical ±1.5 dB typical
In-Band Spurious		-60 dBc max., Signal-related -70 dBc max., Non-Signal-related
Harmonics		-55 dBc typical, -45 dBc max., at IF linear operation
Noise Figure	At maximum gain	15 dB typical, 16 dB max.
Power	Voltage Power	12 VDC 12 W
Temperature Range	Operating Storage	0 °C to +50 °C -40 °C to +85 °C

## Reference Performance

Parameter	Notes	Specification
<b>Internal Reference Standard</b> Aging per day Aging after 10 years	0 °C to +50 °C	±30 ppb typical ±1 ppb typical ±500 ppb typical
<b>External Reference Requirements</b> Frequency Frequency Tolerance Power Level Impedance Ref PLL Bandwidth Ext. Ref. Phase Noise Req.	All RF bands  10 Hz Offset 100 Hz Offset 1 kHz Offset 10 kHz Offset	5 or 10 MHz ±0.5 ppm -5 dBm min., +5 dBm max., At module 50 ohms typical 10 Hz -105 dBm/Hz -135 dBm/Hz -145 dBm/Hz -150 dBm/Hz

Upconverter Module Performance

Parameter	Notes	Specification
RF Input Power		-10 dBm at maximum gain
RF Input VSWR		1.5:1 max. ratio 14 dB Return Loss min.
RF Output VSWR		1.25:1 max. ratio 19.1 dB Return Loss min.
LO Leakage		-50 dBm max. at RF Output
Reference input Frequency		5 or 10 MHz typical, Auto Detect
Reference input Power		-7.5 dBm min., 0 dBm typical, +7.5 dBm max., At module
Power Output at 1dB compression (P <sub>1dB</sub> )	RF Output, at max. gain	+15 dBm min., +17 dBm typical
3 <sup>rd</sup> Order Output Intercept Point	RF Output, at max. gain	+26 dBm min., +27 dBm typical
Gain		24 dB min., 26 dB typical, 30 dB max., at max. gain setting
Gain Step Resolution		0.1 dB typical
Adjustable Gain Range		25 dB typical
Gain Flatness		±1 dB over the full band ±0.25 dB per 40 MHz
Gain Stability	Over temperature Per week, Constant temperature Per week and over temperature	±1 dB typical ±0.5 dB typical ±1.5 dB typical
In-Band Spurious		-60 dBc max., Signal-related -70 dBm max., Non-Signal-related
Noise Figure	At maximum gain	15 dB typical, 16 dB max.
Power	Voltage Power	12 VDC 12 W
Temperature Range	Operating Storage	0°C to +50°C -40°C to +85°C

Reference Performance

Parameter	Notes	Specification
Internal Reference Standard Aging per day Aging after 10 years	0°C to +50°C	±30 ppb typical ±1 ppb typical ±500 ppb typical
External Reference Requirements Frequency Frequency Tolerance Power Level Impedance Ext. Ref. Phase Noise Req.	All RF bands  10 Hz Offset 100 Hz Offset 1 kHz Offset 10 kHz Offset	5 or 10 MHz ±0.5 ppm -5 dBm min., +5 dBm max., At module 50 ohms typical -105 dBm/Hz -135 dBm/Hz -145 dBm/Hz -150 dBm/Hz

## Phase Noise Performance

Maximum dBc/Hz at	Downconverter	Upconverter
10 Hz Offset	-36	-36
100 Hz Offset	-66	-66
1 kHz Offset	-76	-76
10 kHz Offset	-86	-86
100 kHz Offset	-96	-96
1 MHz Offset	-106	-106

## System Performance

The redundant modular block downconverter or upconverter system generally has the same performance as the individual converter modules with the following exceptions:

Parameter	Specification
RF port VSWR	1.3:1 max. (17.7 dB RL)
IF port VSWR	1.6:1 max. (12.7 dB RL)
System RF Losses (typ.)	2 dB
System IF Losses (typ.)	1 dB
Gain Flatness (typ.)	Add $\pm 0.3$ dB to module specification
Noise Figure	Add +2 dB to module specification
Reference Input Power	0 to +10 dBm

## Power Supply

Parameter	Specification
AC Input (dual line input)	90-264 Vac, 47-63 Hz; 60 W typical
DC Output	12 V, 250 W over 0 to +50 °C

## Connector Interfaces

Parameter	Specification
RF/IF Input*	Type N, 50 ohms (standard); SMA, 50 ohms (option)
IF/RF Output*	Type N, 50 ohms (standard); SMA, 50 ohms (option)
10 MHz External Reference Input	BNC Female
Network	RJ-45/CAT 5 Ethernet
Serial I/O	DB-9 (RS-232, RS-422, RS-485:2, RS-485:4)

\* Use an adapter or transformer (not supplied) if interfacing to 75 ohm equipment is required.

Outline Drawing

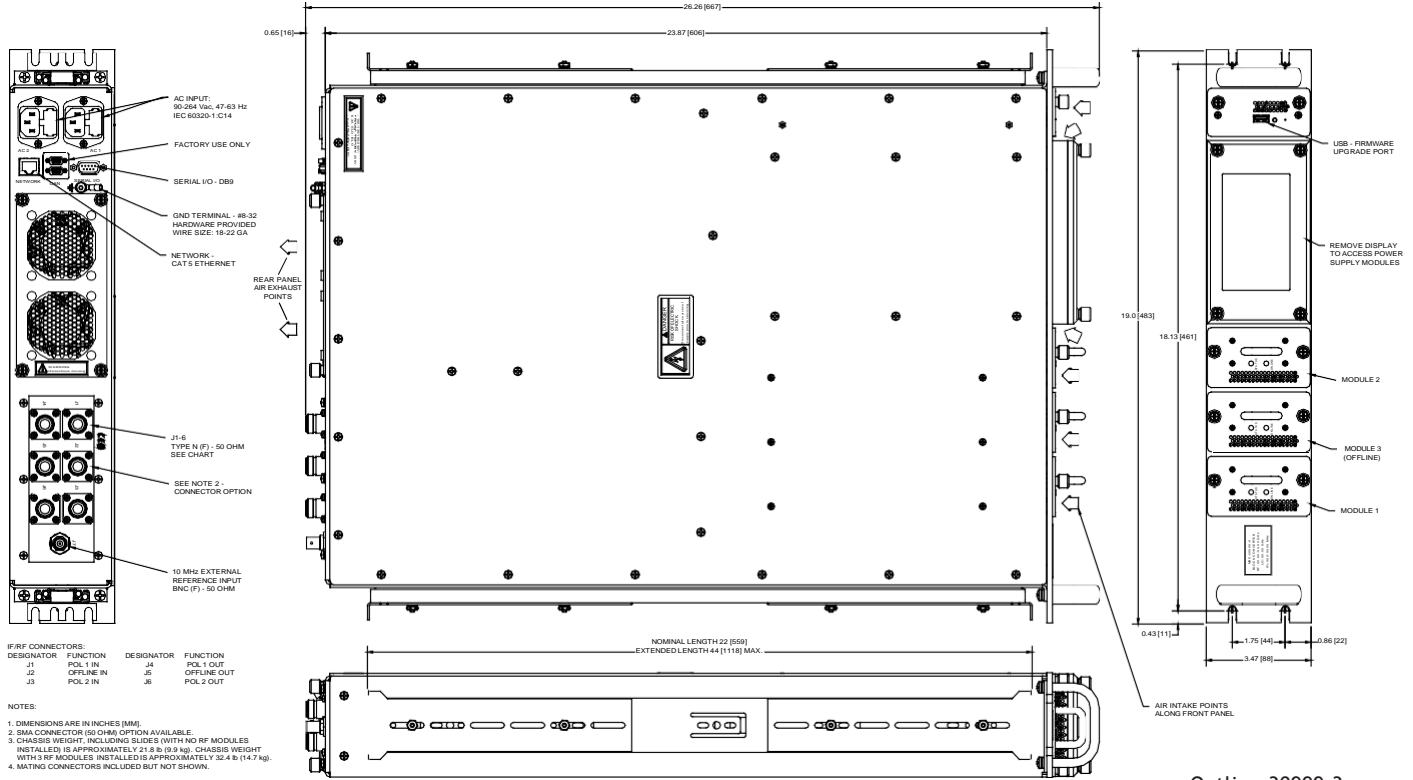

Part Number/Ordering Information

**Top-Level Configuration** Includes rack chassis with 2 power supply modules and choice of 1 (single-thread), 2 (1:1 redundant), or 3 (1:2 redundant) RF modules:

**MBC-**

**Configuration**

- Single-thread, no redundancy (1 RF module).... X
- 1:1 Redundant (2 identical RF modules) ..... 1
- 1:2 Redundant (3 identical RF modules) ..... 2

**Module Identifier (see below)..... XXXX**

**Rear Panel RF connectors**

- Type N, 50 ohms (Standard) ..... X
- SMA, 50 ohms (Option)..... 1

**RF Modules.....** To order single modules separately:

**BCM-**

**Downconverters**

- Ku-Band**
- 10.70-11.75 GHz in, 9.75 GHz LO, 950-2000 MHz out DKFX
- 11.70-12.75 GHz in, 10.75 GHz LO, 950-2000 MHz out DKJX

**Upconverters**

- Ku-Band**
- 950-1700 MHz in, 12.80 GHz LO, 13.75-14.50 GHz out UKBX

**Spare Kit**

Includes 1 Fan Assembly, 1 Power Supply Module, 1 Logic Module, and 1 Display Module. Converter modules sold separately.

Note: Standard configuration includes only one type of RF module per chassis.

Note: To order a blank module cover plate, use part number MPAN-30281.

PS modules can also be ordered separately, part number AMAX-30271-1.

10880 Wilshire Blvd Los Angeles CA 90024 USA

Phone: +1.888.315.9545

Email: [contact@orbitalconnect.com](mailto:contact@orbitalconnect.com)

<https://store.orbitalconnect.com>



